

**Difmicro Technolog**

**DIF81F901**

Datasheet

## Content

DIF81F901 Product characteristics.....	1
Pin Diagram.....	3
CPU Kernel.....	5
DEVICE OVERVIEW .....	5
MEMORY ORGANIZATION .....	8
Program Memory Organization .....	8
Data Memory Organization .....	8
GENERAL PURPOSE REGISTER FILE.....	9
SPECIAL FUNCTION REGISTERS.....	9
Figure 3. DIF81F901 SPECIAL FUNCTION REGISTERS .....	9
ELECTRICAL SPECIFICATIONS.....	13
DC Characteristics: DIF81F901 .....	15
Package Details .....	16



## DIF81F901 Product characteristics

### ● Special Microcontroller Features:

- Only 35 instructions to learn:
  - All single-cycle instructions except branches
- Operating speed:
  - DC- 20 MHz oscillator/clock input
  - DC- 200 ns instruction cycle
- Interrupt capability
- 8-level deep hardware stack
- Direct, Indirect and Relative Addressing modes

### ● Special single chip microcomputer function:

- Precision Internal Oscillator:
  - Factory calibrated to  $\pm 1\%$
  - Software selectable frequency range of 8 MHz to 31 kHz
  - Software tunable
  - Two-Speed Start-up mode
  - Crystal fail detect for critical applications
  - Clock mode switching during operation for power savings
- Power-Saving Sleep mode
- Wide operating voltage range (2.0V-5.5V)
- Industrial and Extended Temperature range
- Power-on Reset (POR)
- Power-up Timer (PWRT) and Oscillator Start-up Timer (OST)
- Brown-out Reset (BOR) with software control option
- Enhanced low-current Watchdog Timer (WDT) with on-chip oscillator (software selectable nominal 268 seconds with full prescaler) with software enable
- Multiplexed Master Clear with pull-up/input pin
- Programmable code protection
- High Endurance Flash/EEPROM cell:
  - 100,000 write Flash endurance
  - 1,000,000 write EEPROM endurance
  - Flash/Data EEPROM retention: > 40 years
- Program memory Read/Write during run time
- In-Circuit Debugger (on board)

### ● Low-Power Features:

- Standby Current:
  - 50 nA @ 2.0V, typical
- Operating Current:
  - 11 uA @ 32 kHz, 2.0V, typical
  - 220 uA @ 4 MHz, 2.0V, typical
- Watchdog Timer Current:
  - 1 uA @ 2.0V, typical



### ● Peripheral Features

- 24/35 I/O pins with individual direction control:
  - High current source/sink for direct LED drive
  - Interrupt-on-Change pin
  - Individually programmable weak pull-ups
  - Ultra Low-Power Wake-up (ULPWU)
- Analog Comparator module with:
  - Two analog comparators
  - Programmable on-chip voltage reference (CVREF) module (% of VDD)
  - Fixed voltage reference (0.6V)
  - Comparator inputs and outputs externally accessible
  - SR Latch mode
  - External Timer1 Gate (count enable)
- A/D Converter:
  - 10-bit resolution and 11/14 channels
- Timer0: 8-bit timer/counter with 8-bit programmable prescaler
- Enhanced Timer1:
  - 16-bit timer/counter with prescaler
  - External Gate Input mode
  - Dedicated low-power 32 kHz oscillator
- Timer2: 8-bit timer/counter with 8-bit period register, prescaler and postscaler
- Enhanced Capture, Compare, PWM+ module:
  - 16-bit Capture, max. resolution 12.5 ns
  - Compare, max. resolution 200 ns
  - 10-bit PWM with 1, 2 or 4 output channels, programmable "dead time", max. frequency 20 kHz
  - PWM output steering control
- Capture, Compare, PWM module:
  - 16-bit Capture, max. resolution 12.5 ns
  - 16-bit Compare, max. resolution 200 ns
  - 10-bit PWM, max. frequency 20 kHz
- Enhanced USART module:
  - Supports RS-485, RS-232, and LIN 2.0
  - Auto-Baud Detect
  - Auto-Wake-Up on Start bit
- In-Circuit Serial Programming (ICSP) via two pins
- Master Synchronous Serial Port (MSSP) module supporting 3-wire SPI (all 4 modes) and I2C Master and Slave Modes with I2C address mask.

Device	Program Memory	Data Memory		I/O	10-bit A/D (ch)	ECCP/ CCP	EUSART	MSSP	Comparators	Timers 8/16-bit
	Flash (words)	SRAM (bytes)	EEPROM (bytes)							
DIF81F901	4096	256	256	24	11	1/1	1	1	2	2/1



## Pin Diagram

DIF81F901DI(28-pin DIP),  
DIF81F901SI(28-pin SOP),  
DIF81F901XI(28-pin SSOP)

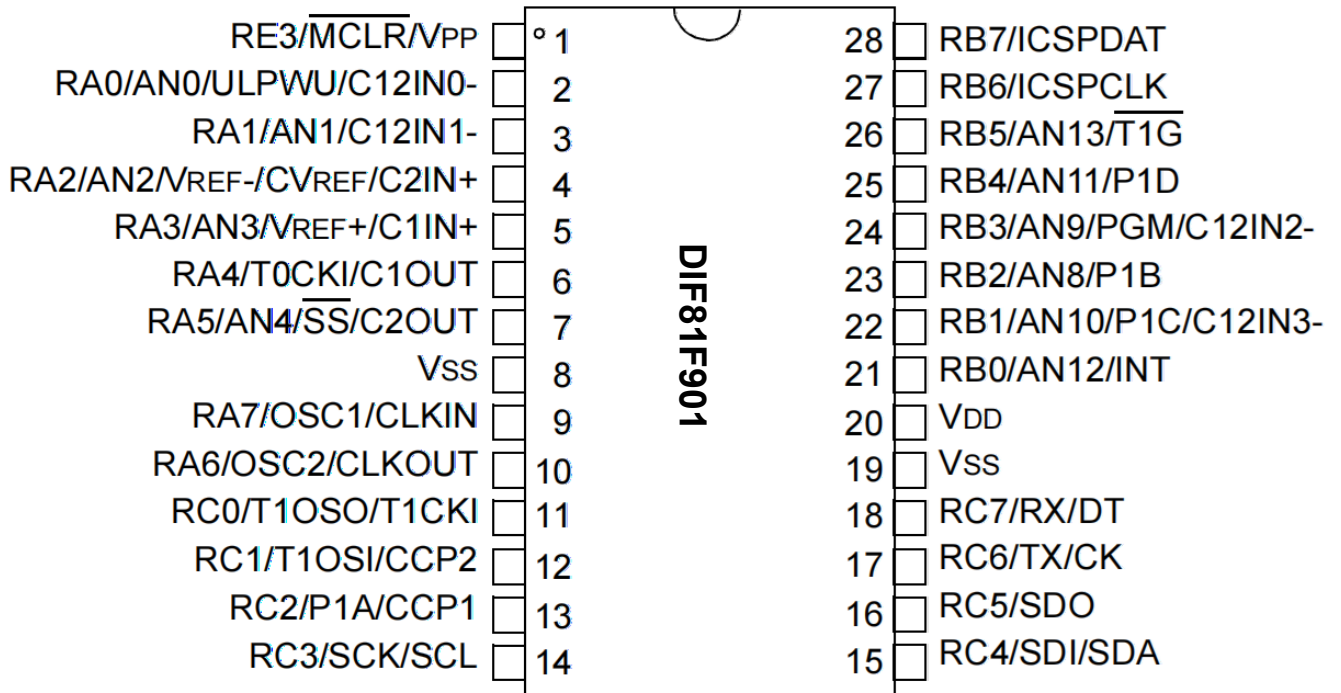

DIFM Tech



Table 1. DIF81F901 28-PIN SUMMARY (PDIP, SOIC, SSOP)

I/O	Pin	Analog	Comparators	Timers	ECCP	EUSART	MSSP	Interrupt	Pull-up	Basic
RA0	2	AN0/ULPWU	C12IN0-	—	—	—	—	—	—	—
RA1	3	AN1	C12IN1-	—	—	—	—	—	—	—
RA2	4	AN2	C2IN+	—	—	—	—	—	—	VREF-/CVREF
RA3	5	AN3	C1IN+	—	—	—	—	—	—	VREF+
RA4	6	—	C1OUT	T0CKI	—	—	—	—	—	—
RA5	7	AN4	C2OUT	—	—	—	SS	—	—	—
RA6	10	—	—	—	—	—	—	—	—	OSC2/CLKOUT
RA7	9	—	—	—	—	—	—	—	—	OSC1/CLKIN
RB0	21	AN12	—	—	—	—	—	IOC/INT	Y	—
RB1	22	AN10	C12IN3-	—	P1C	—	—	IOC	Y	—
RB2	23	AN8	—	—	P1B	—	—	IOC	Y	—
RB3	24	AN9	C12IN2-	—	—	—	—	IOC	Y	PGM
RB4	25	AN11	—	—	P1D	—	—	IOC	Y	—
RB5	26	AN13	—	T1G	—	—	—	IOC	Y	—
RB6	27	—	—	—	—	—	—	IOC	Y	ICSPCLK
RB7	28	—	—	—	—	—	—	IOC	Y	ICSPDAT
RC0	11	—	—	T1OSO/T1CKI	—	—	—	—	—	—
RC1	12	—	—	T1OSI	CCP2	—	—	—	—	—
RC2	13	—	—	—	CCP1/P1A	—	—	—	—	—
RC3	14	—	—	—	—	—	SCK/SCL	—	—	—
RC4	15	—	—	—	—	—	SDI/SDA	—	—	—
RC5	16	—	—	—	—	—	SDO	—	—	—
RC6	17	—	—	—	—	TX/CK	—	—	—	—
RC7	18	—	—	—	—	RX/DT	—	—	—	—
RE3	1	—	—	—	—	—	—	—	Y <sup>(1)</sup>	MCLR/VPP
—	20	—	—	—	—	—	—	—	—	VDD
—	8	—	—	—	—	—	—	—	—	VSS
—	19	—	—	—	—	—	—	—	—	VSS

Note 1: Pull-up activated only with external MCLR configuration.



### CPU Kernel

### DEVICE OVERVIEW

The DIF81F901 is covered by this data sheet. The DIF81F901 is available in 28-pin DIP, SOIC, SSOP packages. **Figure 1** shows the block diagram of DIF81F901 device. **Table 2** show the corresponding pinout descriptions.

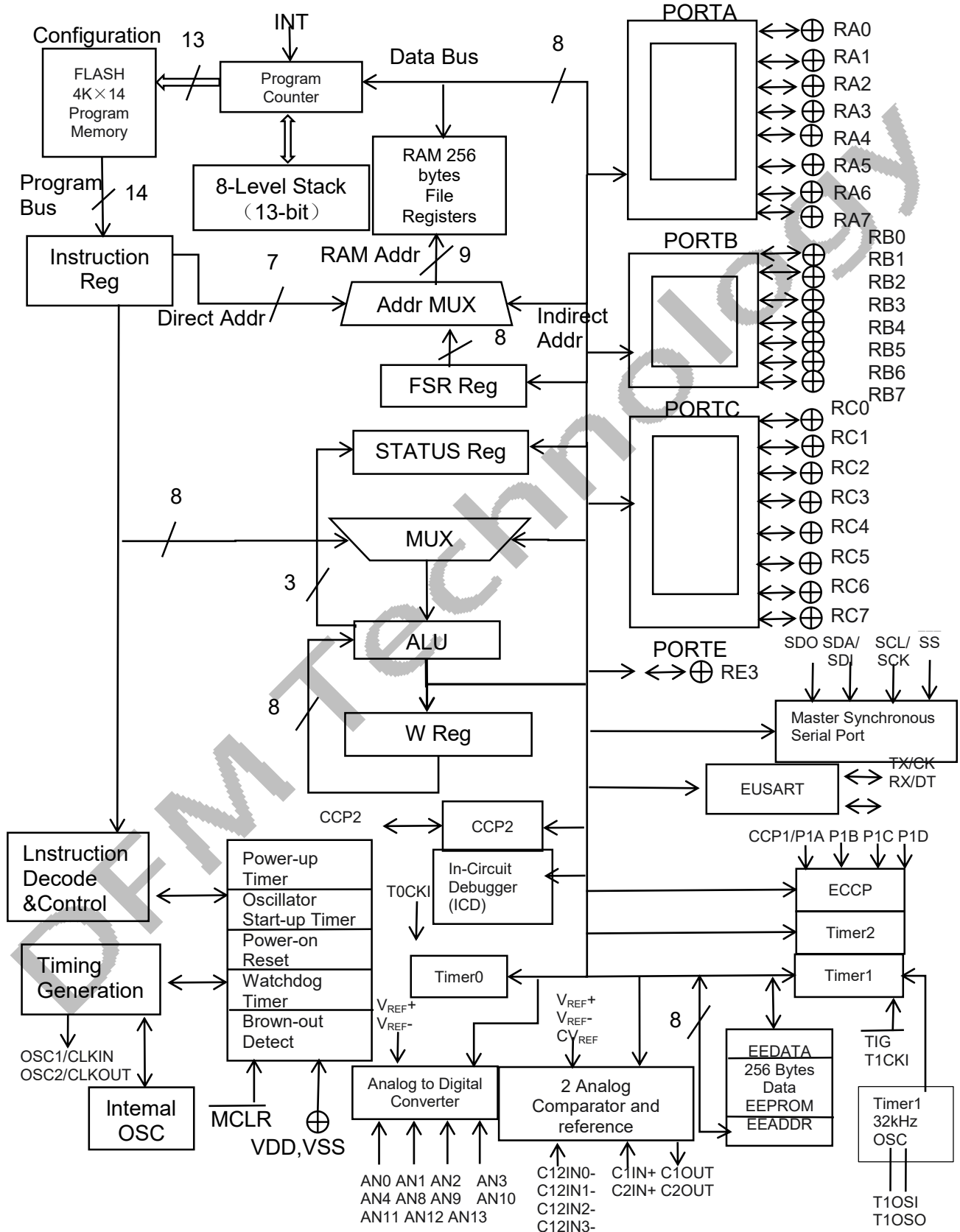

Figure 1. DIF81F901 BLOCK DIAGRAM



Table 2. DIF81F901 PINOUT DESCRIPTION

Name	Function	Input Type	Output Type	Description
RA0/AN0/ULPWU/C12IN0-	RA0	TTL	CMOS	General purpose I/O.
	AN0	AN	—	A/D Channel 0 input.
	ULPWU	AN	—	Ultra Low-Power Wake-up input.
	C12IN0-	AN	—	Comparator C1 or C2 negative input.
RA1/AN1/C12IN1-	RA1	TTL	CMOS	General purpose I/O. Individually enabled pull-up.
	AN1	AN	—	A/D Channel 1 input.
	C12IN1-	AN	—	Comparator C1 or C2 negative input.
RA2/AN2/VREF-/CVREF/C2IN+	RA2	TTL	CMOS	General purpose I/O.
	AN2	AN	—	A/D Channel 2.
	VREF-	AN	—	A/D Negative Voltage Reference input.
	CVREF	—	AN	Comparator Voltage Reference output.
	C2IN+	AN	—	Comparator C2 positive input.
RA3/AN3/VREF+/C1IN+	RA3	TTL	—	General purpose I/O.
	AN3	AN	—	A/D Channel 3.
	VREF+	AN	—	Programming voltage.
	C1IN+	AN	—	Comparator C1 positive input.
RA4/T0CKI/C1OUT	RA4	TTL	CMOS	General purpose I/O. Individually enabled pull-up.
	T0CKI	ST	—	Timer0 clock input.
	C1OUT	—	CMOS	Comparator C1 output.
RA5/AN4/SS/C2OUT	RA5	TTL	CMOS	General purpose I/O.
	AN4	AN	—	A/D Channel 4.
	SS	ST	—	Slave Select input.
	C2OUT	—	CMOS	Comparator C2 output.
RA6/OSC2/CLKOUT	RA6	TTL	CMOS	General purpose I/O.
	OSC2	—	XTAL	Master Clear with internal pull-up.
	CLKOUT	—	CMOS	Fosc/4 output.
RA7/OSC1/CLKIN	RA7	TTL	CMOS	General purpose I/O.
	OSC1	XTAL	—	Crystal/Resonator.
	CLKIN	ST	—	External clock input/RC oscillator connection.
RB0/AN12/INT	RB0	TTL	CMOS	General purpose I/O. Individually controlled interrupt-on-change. Individually enabled pull-up.
	AN12	AN	—	A/D Channel 12.
	INT	ST	—	External interrupt.
RB1/AN10/P1C/C12IN3-	RB1	TTL	CMOS	General purpose I/O. Individually controlled interrupt-on-change. Individually enabled pull-up.
	AN10	AN	—	A/D Channel 10.
	P1C	—	CMOS	PWM output.
	C12IN3-	AN	—	Comparator C1 or C2 negative input.
RB2/AN8/P1B	RB2	TTL	CMOS	General purpose I/O. Individually controlled interrupt-on-change. Individually enabled pull-up.
	AN8	AN	—	A/D Channel 8.
	P1B	—	CMOS	PWM output.

Legend: AN = Analog input or output

CMOS = CMOS compatible input or output

OD = Open Drain

TTL = TTL compatible input

ST = Schmitt Trigger input with CMOS levels

HV = High Voltage

XTAL = Crystal





Name	Function	Input Type	Output Type	Description
RB3/AN9/PGM/C12IN2-	RB3	TTL	CMOS	General purpose I/O. Individually controlled interrupt-on-change. Individually enabled pull-up.
	AN9	AN	—	A/D Channel 9.
	PGM	ST	—	Low-voltage ICSP Programming enable pin.
	C12IN2-	AN	—	Comparator C1 or C2 negative input.
RB4/AN11/P1D	RB4	TTL	CMOS	General purpose I/O. Individually controlled interrupt-on-change. Individually enabled pull-up.
	AN11	AN	—	A/D Channel 11.
	P1D	—	CMOS	PWM output.
RB5/AN13/T1G	RB5	TTL	CMOS	General purpose I/O. Individually controlled interrupt-on-change. Individually enabled pull-up.
	AN13	AN	—	A/D Channel 13.
	T1G	ST	—	Timer1 Gate input.
RB6/ICSPCLK	RB6	TTL	CMOS	General purpose I/O. Individually controlled interrupt-on-change. Individually enabled pull-up.
	ICSPCLK	ST	—	Serial Programming Clock.
RB7/ICSPDAT	RB7	TTL	CMOS	General purpose I/O. Individually controlled interrupt-on-change. Individually enabled pull-up.
	ICSPDAT	ST	CMOS	ICSP Data I/O.
RC0/T1OSO/T1CKI	RC0	ST	CMOS	General purpose I/O.
	T1OSO	—	CMOS	Timer1 oscillator output.
	T1CKI	ST	—	Timer1 clock input.
RC1/T1OSI/CCP2	RC1	ST	CMOS	General purpose I/O.
	T1OSI	ST	—	Timer1 oscillator input.
	CCP2	ST	CMOS	Capture/Compare/PWM2.
RC2/P1A/CCP1	RC2	ST	CMOS	General purpose I/O.
	P1A	—	CMOS	PWM output.
	CCP1	ST	CMOS	Capture/Compare/PWM1.
RC3/SCK/SCL	RC3	ST	CMOS	General purpose I/O.
	SCK	ST	CMOS	SPI clock.
	SCL	ST	OD	I <sup>2</sup> C clock.
RC4/SDI/SDA	RC4	ST	CMOS	General purpose I/O.
	SDI	ST	—	SPI data input.
	SDA	ST	OD	I <sup>2</sup> C data input/output.
RC5/SDO	RC5	ST	CMOS	General purpose I/O.
	SDO	—	CMOS	SPI data output.
RC6/TX/CK	RC6	ST	CMOS	General purpose I/O.
	TX	—	CMOS	EUSART asynchronous transmit.
	CK	ST	CMOS	EUSART synchronous clock.
RC7/RX/DT	RC7	ST	CMOS	General purpose I/O.
	RX	ST	—	EUSART asynchronous input.
	DT	ST	CMOS	EUSART synchronous data.
RE3/MCLR/VPP	RE3	TTL	—	General purpose input.
	MCLR	ST	—	Master Clear with internal pull-up.
	VPP	HV	—	Programming voltage.
VSS	VSS	Power	—	Ground reference.
VDD	VDD	Power	—	Positive supply.

Legend: AN = Analog input or output

CMOS = CMOS compatible input or output

OD = Open Drain

TTL = TTL compatible input

ST = Schmitt Trigger input with CMOS levels

HV = High Voltage

XTAL = Crystal



### MEMORY ORGANIZATION

#### Program Memory Organization

The DIF81F901 has a 13-bit program counter capable of addressing a 4K x 14 (0000h-0FFFh) for the DIF81F901 program memory space. Accessing a location above these boundaries will cause a wraparound within the first 8K x 14 space. The Reset vector is at 0000h and the interrupt vector is at 0004h.

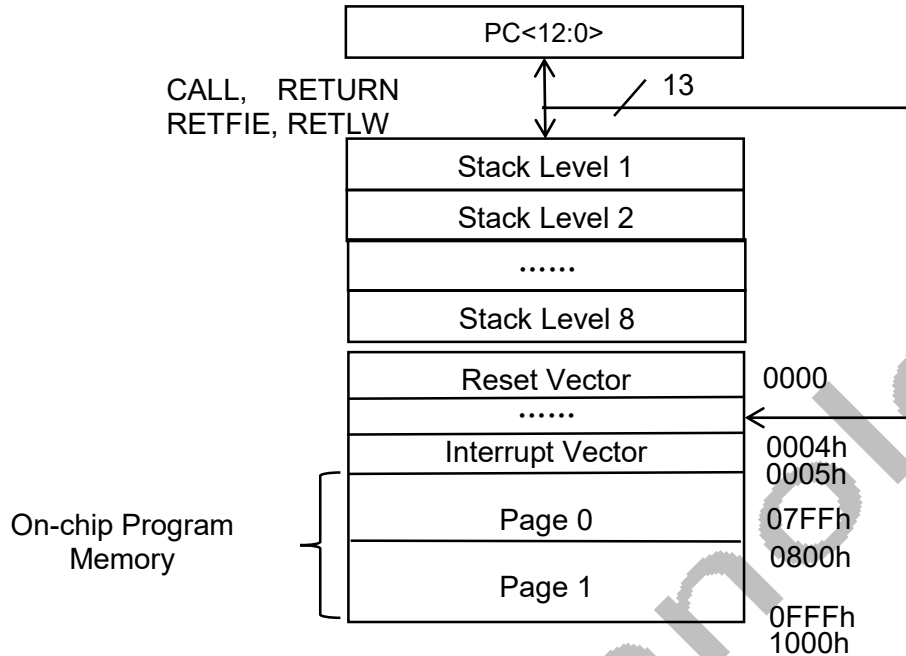

Figure 2. PROGRAM MEMORY MAP AND STACK FOR THE DIF81F901

#### Data Memory Organization

The data memory is partitioned into four banks which contain the General Purpose Registers (GPR) and the Special Function Registers (SFR). The Special Function Registers are located in the first 32 locations of each bank. The General Purpose Registers, implemented as static RAM, are located in the last 96 locations of each Bank. Register locations F0h-FFh in Bank 1, 170h-17Fh in Bank 2 and 1F0h-1FFh in Bank 3, point to addresses 70h-7Fh in Bank 0. The actual number of General Purpose Registers (GPR) implemented in each Bank depends on the device. All other RAM is unimplemented and returns '0' when read. RP<1:0> of the STATUS register are the bank select bits.

RP1	RP0		
0	0	→	Bank 0 is selected
0	1	→	Bank 1 is selected
1	0	→	Bank 2 is selected
1	1	→	Bank 3 is selected



## GENERAL PURPOSE REGISTER FILE

The register file is organized as 256 x 8 in the DIF81F901. Each register is accessed, either directly or indirectly, through the File Select Register (FSR).

### SPECIAL FUNCTION REGISTERS

The Special Function Registers are registers used by the CPU and peripheral functions for controlling the desired operation of the device. These registers are static RAM.

The special registers can be classified into two sets: core and peripheral. The Special Function Registers associated with the “core” are described in this section. Those related to the operation of the peripheral features are described in the section of that peripheral feature.

File	Address	File	Address	File	Address	File	Address
Indirect addr. <sup>(1)</sup>	00h	Indirect addr. <sup>(1)</sup>	80h	Indirect addr. <sup>(1)</sup>	100h	Indirect addr. <sup>(1)</sup>	180h
TMR0	01h	OPTION_REG	81h	TMR0	101h	OPTION_REG	181h
PCL	02h	PCL	82h	PCL	102h	PCL	182h
STATUS	03h	STATUS	83h	STATUS	103h	STATUS	183h
FSR	04h	FSR	84h	FSR	104h	FSR	184h
PORTA	05h	TRISA	85h	WDTCON	105h	SRCON	185h
PORTB	06h	TRISB	86h	PORTB	106h	TRISB	186h
PORTC	07h	TRISC	87h	CM1CON0	107h	BAUDCTL	187h
PORTD <sup>(2)</sup>	08h	TRISD <sup>(2)</sup>	88h	CM2CON0	108h	ANSEL	188h
PORTE	09h	TRISE	89h	CM2CON1	109h	ANSELH	189h
PCLATH	0Ah	PCLATH	8Ah	PCLATH	10Ah	PCLATH	18Ah
INTCON	0Bh	INTCON	8Bh	INTCON	10Bh	INTCON	18Bh
PIR1	0Ch	PIE1	8Ch	EEDAT	10Ch	EECON1	18Ch
PIR2	0Dh	PIE2	8Dh	EEADR	10Dh	EECON2 <sup>(1)</sup>	18Dh
TMR1L	0Eh	PCON	8Eh	EEADRH	10Eh	Reserved	18Eh
TMR1H	0Fh	OSCCON	8Fh		10Fh	Reserved	18Fh
T1CON	10h	OSCTUNE	90h		110h		190h
TMR2	11h	SSPCON2	91h		111h		191h
T2CON	12h	PR2	92h		112h		192h
SSPBUF	13h	SSPADD	93h		113h		193h
SSPCON	14h	SSPSTAT	94h		114h		194h
CCPR1L	15h	WPUB	95h		115h		195h
CCPR1H	16h	IOCB	96h		116h		196h
CCP1CON	17h	VRCON	97h		117h		197h
RCSTA	18h	TXSTA	98h		118h		198h
TXREG	19h	SPBRG	99h		119h		199h
RCREG	1Ah	SPBRGH	9Ah		11Ah		19Ah
CCPR2L	1Bh	PWM1CON	9Bh		11Bh		19Bh
CCPR2H	1Ch	ECCPAS	9Ch		11Ch		19Ch
CCP2CON	1Dh	PSTRCON	9Dh		11Dh		19Dh
ADRESH	1Eh	ADRESL	9Eh		11Eh		19Eh
ADCON0	1Fh	ADCON1	9Fh		11Fh		19Fh
	20h		A0h		120h		1A0h
General Purpose Registers		General Purpose Registers		General Purpose Registers			
96 Bytes		80 Bytes		80 Bytes			
	7Fh	accesses 70h-7Fh	EFh	accesses 70h-7Fh	16Fh		1EFh
			F0h		170h	accesses 70h-7Fh	1F0h
			FFh		17Fh		1FFh

Figure 3. DIF81F901 SPECIAL FUNCTION REGISTERS



**Table 3. DIF81F901 SPECIAL FUNCTION REGISTERS SUMMARY BANK 0**

Addr	Name	Bit 7	Bit 6	Bit 5	Bit 4	Bit 3	Bit 2	Bit 1	Bit 0	Value on POR, BOR
<b>Bank 0</b>										
00h	INDF	Addressing this location uses contents of FSR to address data memory (not a physical register)								xxxx xxxx
01h	TMR0	Timer0 Module Register								xxxx xxxx
02h	PCL	Program Counter's (PC) Least Significant Byte								0000 0000
03h	STATUS	IRP	RP1	RP0	$\overline{TO}$	$\overline{PD}$	Z	DC	C	0001 1xxx
04h	FSR	Indirect Data Memory Address Pointer								xxxx xxxx
05h	PORTA <sup>(3)</sup>	RA7	RA6	RA5	RA4	RA3	RA2	RA1	RA0	xxxx xxxx
06h	PORTB <sup>(3)</sup>	RB7	RB6	RB5	RB4	RB3	RB2	RB1	RB0	xxxx xxxx
07h	PORTC <sup>(3)</sup>	RC7	RC6	RC5	RC4	RC3	RC2	RC1	RC0	xxxx xxxx
08h	PORTD <sup>(3,4)</sup>	RD7	RD6	RD5	RD4	RD3	RD2	RD1	RD0	xxxx xxxx
09h	PORTE <sup>(3)</sup>	—	—	—	—	RE3	RE2 <sup>(4)</sup>	RE1 <sup>(4)</sup>	RE0 <sup>(4)</sup>	--- xxxx
0Ah	PCLATH	—	—	—	Write Buffer for upper 5 bits of Program Counter					---0 0000
0Bh	INTCON	GIE	PEIE	T0IE	INTE	RBIE	T0IF	INTF	RBIF <sup>(1)</sup>	0000 000x
0Ch	PIR1	—	ADIF	RCIF	TXIF	SSPIF	CCP1IF	TMR2IF	TMR1IF	-000 0000
0Dh	PIR2	OSFIF	C2IF	C1IF	EEIF	BCLIF	ULPWUIF	—	CCP2IF	0000 00-0
0Eh	TMR1L	Holding Register for the Least Significant Byte of the 16-bit TMR1 Register								xxxx xxxx
0Fh	TMR1H	Holding Register for the Most Significant Byte of the 16-bit TMR1 Register								xxxx xxxx
10h	T1CON	T1GINV	TMR1GE	T1CKPS1	T1CKPS0	T1OSCEN	$\overline{T1SYNC}$	TMR1CS	TMR1ON	0000 0000
11h	TMR2	Timer2 Module Register								0000 0000
12h	T2CON	—	TOUTPS3	TOUTPS2	TOUTPS1	TOUTPS0	TMR2ON	T2CKPS1	T2CKPS0	-000 0000
13h	SSPBUF	Synchronous Serial Port Receive Buffer/Transmit Register								xxxx xxxx
14h	SSPCON <sup>(2)</sup>	WCOL	SSPOV	SSPEN	CKP	SSPM3	SSPM2	SSPM1	SSPM0	0000 0000
15h	CCPR1L	Capture/Compare/PWM Register 1 Low Byte (LSB)								xxxx xxxx
16h	CCPR1H	Capture/Compare/PWM Register 1 High Byte (MSB)								xxxx xxxx
17h	CCP1CON	P1M1	P1M0	DC1B1	DC1B0	CCP1M3	CCP1M2	CCP1M1	CCP1M0	0000 0000
18h	RCSTA	SPEN	RX9	SREN	CREN	ADDEN	FERR	OERR	RX9D	0000 000x
19h	TXREG	EUSART Transmit Data Register								0000 0000
1Ah	RCREG	EUSART Receive Data Register								0000 0000
1Bh	CCPR2L	Capture/Compare/PWM Register 2 Low Byte (LSB)								xxxx xxxx
1Ch	CCPR2H	Capture/Compare/PWM Register 2 High Byte (MSB)								xxxx xxxx
1Dh	CCP2CON	—	—	DC2B1	DC2B0	CCP2M3	CCP2M2	CCP2M1	CCP2M0	--00 0000
1Eh	ADRESH	A/D Result Register High Byte								xxxx xxxx
1Fh	ADCON0	ADCS1	ADCS0	CHS3	CHS2	CHS1	CHS0	$\overline{GO/DONE}$	ADON	0000 0000

**Legend:** - = Unimplemented locations read as '0', u = unchanged, x = unknown, q = value depends on condition, shaded = unimplemented

**Note 1:** MCLR and WDT Reset do not affect the previous value data latch. The RBIF bit will be cleared upon Reset but will set again if the mismatch exists.

**2:** When SSPCON register bits SSPM<3:0> = 1001, any reads or writes to the SSPADD SFR address are accessed through the SSPMSK register. See Registers • and 13-4 for more detail.

**3:** Port pins with analog functions controlled by the ANSEL and ANSELH registers will read '0' immediately after a Reset even though the data latches are either undefined (POR) or unchanged (other Resets).



Table 4.DIF81F901 SPECIAL FUNCTION REGISTERS SUMMARY BANK 1

Addr	Name	Bit 7	Bit 6	Bit 5	Bit 4	Bit 3	Bit 2	Bit 1	Bit 0	Value on POR, BOR
<b>Bank 1</b>										
80h	INDF	Addressing this location uses contents of FSR to address data memory (not a physical register)								xxxx xxxx
81h	OPTION_REG	RBP <sub>U</sub>	INTEDG	T0CS	T0SE	PSA	PS2	PS1	PS0	1111 1111
82h	PCL	Program Counter's (PC) Least Significant Byte								0000 0000
83h	STATUS	IRP	RP1	RP0	$\overline{TO}$	$\overline{PD}$	Z	DC	C	0001 1xxx
84h	FSR	Indirect Data Memory Address Pointer								xxxx xxxx
85h	TRISA	TRISA7	TRISA6	TRISA5	TRISA4	TRISA3	TRISA2	TRISA1	TRISA0	1111 1111
86h	TRISB	TRISB7	TRISB6	TRISB5	TRISB4	TRISB3	TRISB2	TRISB1	TRISB0	1111 1111
87h	TRISC	TRISC7	TRISC6	TRISC5	TRISC4	TRISC3	TRISC2	TRISC1	TRISC0	1111 1111
88h	TRISD <sup>(3)</sup>	TRISD7	TRISD6	TRISD5	TRISD4	TRISD3	TRISD2	TRISD1	TRISD0	1111 1111
89h	TRISE	—	—	—	—	TRISE3	TRISE2 <sup>(3)</sup>	TRISE1 <sup>(3)</sup>	TRISE0 <sup>(3)</sup>	--- 1111
8Ah	PCLATH	—	—	—	Write Buffer for the upper 5 bits of the Program Counter					---0 0000
8Bh	INTCON	GIE	PEIE	TOIE	INTE	RBIE	T0IF	INTF	RBIF <sup>(1)</sup>	0000 000x
8Ch	PIE1	—	ADIE	RCIE	TXIE	SSPIE	CCP1IE	TMR2IE	TMR1IE	-000 0000
8Dh	PIE2	OSFIE	C2IE	C1IE	EEIE	BCLIE	ULPWUIE	—	CCP2IE	0000 00-0
8Eh	PCON	—	—	ULPWUE	SBOREN	—	—	$\overline{POR}$	$\overline{BOR}$	--01 --qq
8Fh	OSCCON	—	IRCF2	IRCF1	IRCF0	OSTS	HTS	LTS	SCS	-110 q000
90h	OSCTUNE	—	—	—	TUN4	TUN3	TUN2	TUN1	TUN0	---0 0000
91h	SSPCON2	GCEN	ACKSTAT	ACKDT	ACKEN	RCEN	PEN	RSEN	SEN	0000 0000
92h	PR2	Timer2 Period Register								1111 1111
93h	SSPAD <sup>(2)</sup>	Synchronous Serial Port (I <sup>2</sup> C mode) Address Register								0000 0000
93h	SSPMSK <sup>(2)</sup>	MSK7	MSK6	MSK5	MSK4	MSK3	MSK2	MSK1	MSK0	1111 1111
94h	SSPSTAT	SMP	CKE	$\overline{D/A}$	P	S	$\overline{R/W}$	UA	BF	0000 0000
95h	WPUB	WPUB7	WPUB6	WPUB5	WPUB4	WPUB3	WPUB2	WPUB1	WPUB0	1111 1111
96h	IOCB	IOCB7	IOCB6	IOCB5	IOCB4	IOCB3	IOCB2	IOCB1	IOCB0	0000 0000
97h	VRCON	VREN	VROE	VRR	VRSS	VR3	VR2	VR1	VR0	0000 0000
98h	TXSTA	CSRC	TX9	TXEN	SYNC	SENDB	BRGH	TRMT	TX9D	0000 0010
99h	SPBRG	BRG7	BRG6	BRG5	BRG4	BRG3	BRG2	BRG1	BRG0	0000 0000
9Ah	SPBRGH	BRG15	BRG14	BRG13	BRG12	BRG11	BRG10	BRG9	BRG8	0000 0000
9Bh	PWM1CON	PRSEN	PDC6	PDC5	PDC4	PDC3	PDC2	PDC1	PDC0	0000 0000
9Ch	ECCPAS	ECCPASE	ECCPAS2	ECCPAS1	ECCPAS0	PSSAC1	PSSAC0	PSSBD1	PSSBD0	0000 0000
9Dh	PSTRCON	—	—	—	STRSYNC	STRD	STRC	STRB	STRA	---0 0001
9Eh	ADRESL	A/D Result Register Low Byte								xxxx xxxx
9Fh	ADCON1	ADFM	—	VCFG1	VCFG0	—	—	—	—	0-00 ----

**Legend:** - = Unimplemented locations read as '0', u = unchanged, x = unknown, q = value depends on condition, shaded = unimplemented

**Note 1:** MCLR and WDT Reset do not affect the previous value data latch. The RBIF bit will be cleared upon Reset but will set again if the mismatch exists.

**2:** Accessible only when SSPCON register bits SSPM<3:0> = 1001.



**Table 5. DIF81F901 SPECIAL FUNCTION REGISTERS SUMMARY BANK 2**

Addr	Name	Bit 7	Bit 6	Bit 5	Bit 4	Bit 3	Bit 2	Bit 1	Bit 0	Value on POR, BOR
<b>Bank 2</b>										
100h	INDF	Addressing this location uses contents of FSR to address data memory (not a physical register)								xxxx xxxx
101h	TMR0	Timer0 Module Register								xxxx xxxx
102h	PCL	Program Counter's (PC) Least Significant Byte								0000 0000
103h	STATUS	IRP	RP1	RP0	$\overline{TO}$	$\overline{PD}$	Z	DC	C	0001 1xxx
104h	FSR	Indirect Data Memory Address Pointer								xxxx xxxx
105h	WDTCON	—	—	—	WDTPS3	WDTPS2	WDTPS1	WDTPS0	SWDTEN	---0 1000
106h	PORTB	RB7	RB6	RB5	RB4	RB3	RB2	RB1	RB0	xxxx xxxx
107h	CM1CON0	C1ON	C1OUT	C1OE	C1POL	—	C1R	C1CH1	C1CH0	0000 -000
108h	CM2CON0	C2ON	C2OUT	C2OE	C2POL	—	C2R	C2CH1	C2CH0	0000 -000
109h	CM2CON1	MC1OUT	MC2OUT	C1RSEL	C2RSEL	—	—	T1GSS	C2SYNC	0000 --10
10Ah	PCLATH	—	—	—	Write Buffer for the upper 5 bits of the Program Counter				---	0000
10Bh	INTCON	GIE	PEIE	TOIE	INTE	RBIE	TOIF	INTF	RBIF <sup>(1)</sup>	0000 000x
10Ch	EEDAT	EEDAT7	EEDAT6	EEDAT5	EEDAT4	EEDAT3	EEDAT2	EEDAT1	EEDAT0	0000 0000
10Dh	EEADR	EEADR7	EEADR6	EEADR5	EEADR4	EEADR3	EEADR2	EEADR1	EEADR0	0000 0000
10Eh	EEDATH	—	—	EEDATH5	EEDATH4	EEDATH3	EEDATH2	EEDATH1	EEDATH0	--00 0000
10Fh	EEADRH	—	—	—	EEADRH4 <sup>(2)</sup>	EEADRH3	EEADRH2	EEADRH1	EEADRH0	---- 0000

**Legend:** - = Unimplemented locations read as '0', u = unchanged, x = unknown, q = value depends on condition, shaded = unimplemented

**Note 1:** MCLR and WDT Reset do not affect the previous value data latch. The RBIF bit will be cleared upon Reset but will set again if the mismatch exists.

**Table 6. DIF81F901 SPECIAL FUNCTION REGISTERS SUMMARY BANK 3**

Addr	Name	Bit 7	Bit 6	Bit 5	Bit 4	Bit 3	Bit 2	Bit 1	Bit 0	Value on POR, BOR
<b>Bank 3</b>										
180h	INDF	Addressing this location uses contents of FSR to address data memory (not a physical register)								xxxx xxxx
181h	OPTION_REG	$\overline{RBPV}$	INTEDG	T0CS	T0SE	PSA	PS2	PS1	PS0	1111 1111
182h	PCL	Program Counter's (PC) Least Significant Byte								0000 0000
183h	STATUS	IRP	RP1	RP0	$\overline{TO}$	$\overline{PD}$	Z	DC	C	0001 1xxx
184h	FSR	Indirect Data Memory Address Pointer								xxxx xxxx
185h	SRCON	SR1	SR0	C1SEN	C2REN	PULSS	PULSR	—	FVREN	0000 00-0
186h	TRISB	TRISB7	TRISB6	TRISB5	TRISB4	TRISB3	TRISB2	TRISB1	TRISB0	1111 1111
187h	BAUDCTL	ABDOVF	RCIDL	—	SCKP	BRG16	—	WUE	ABDEN	01-0 0-00
188h	ANSEL	ANS7 <sup>(2)</sup>	ANS6 <sup>(2)</sup>	ANS5 <sup>(2)</sup>	ANS4	ANS3	ANS2	ANS1	ANS0	1111 1111
189h	ANSELH	—	—	ANS13	ANS12	ANS11	ANS10	ANS9	ANS8	--11 1111
18Ah	PCLATH	—	—	—	Write Buffer for the upper 5 bits of the Program Counter				---	0000
18Bh	INTCON	GIE	PEIE	TOIE	INTE	RBIE	TOIF	INTF	RBIF <sup>(1)</sup>	0000 000x
18Ch	EECON1	EEPGD	—	—	—	WRERR	WREN	WR	RD	x--- x000
18Dh	EECON2	EEPROM Control Register 2 (not a physical register)								---- ----

**Legend:** - = Unimplemented locations read as '0', u = unchanged, x = unknown, q = value depends on condition, shaded = unimplemented

**Note 1:** MCLR and WDT Reset do not affect the previous value data latch. The RBIF bit will be cleared upon Reset but will set again if the mismatch exists.



## ELECTRICAL SPECIFICATIONS

### Absolute Maximum Ratings(†)

Ambient temperature under bias.....	-40°C to+125°C
Storage temperature.....	-65°C to+150°C
Voltage on VDD with respect to VSS.....	-0.3to+6.5V
Voltage on MCLR with respect to Vss.....	-0.3to +13.5V
Voltage on all other pins with respect to VSS.....	-0.3V to (VDD + 0.3V)
Total power dissipation (1).....	800mW
Maximum current out of VSS pin.....	300 mA
Maximum current into VDD pin.....	250 mA
Input clamp current, I <sub>IK</sub> (V <sub>I</sub> < 0 or V <sub>I</sub> > V <sub>DD</sub> ).....	± 20 mA
Output clamp current, I <sub>OK</sub> (V <sub>o</sub> < 0 or V <sub>o</sub> > V <sub>DD</sub> ).....	± 20 mA
Maximum output current sunk by any I/O pin.....	25 mA
Maximum output current sourced by any I/O pin.....	25 mA
Maximum current sunk by PORTA, PORTB and PORTC .....	25mA
Maximum current sourced PORTA, PORTB and PORTC .....	25mA

**Note 1:** Power dissipation is calculated as follows:  $P_{DIS} = V_{DD} \times \{I_{DD} - \sum I_{OH}\} + \sum \{(V_{DD} - V_{OH}) \times I_{OH}\} + \sum (V_{OL} \times I_{OL})$ .

**NOTICE:** Stresses above those listed under 'Absolute Maximum Ratings' may cause permanent damage to the device. This is a stress rating only and functional operation of the device at those or any other conditions above those indicated in the operation listings of this specification is not implied. Exposure to maximum rating conditions for extended periods may affect device reliability.

DIFM TECHNOLOGY

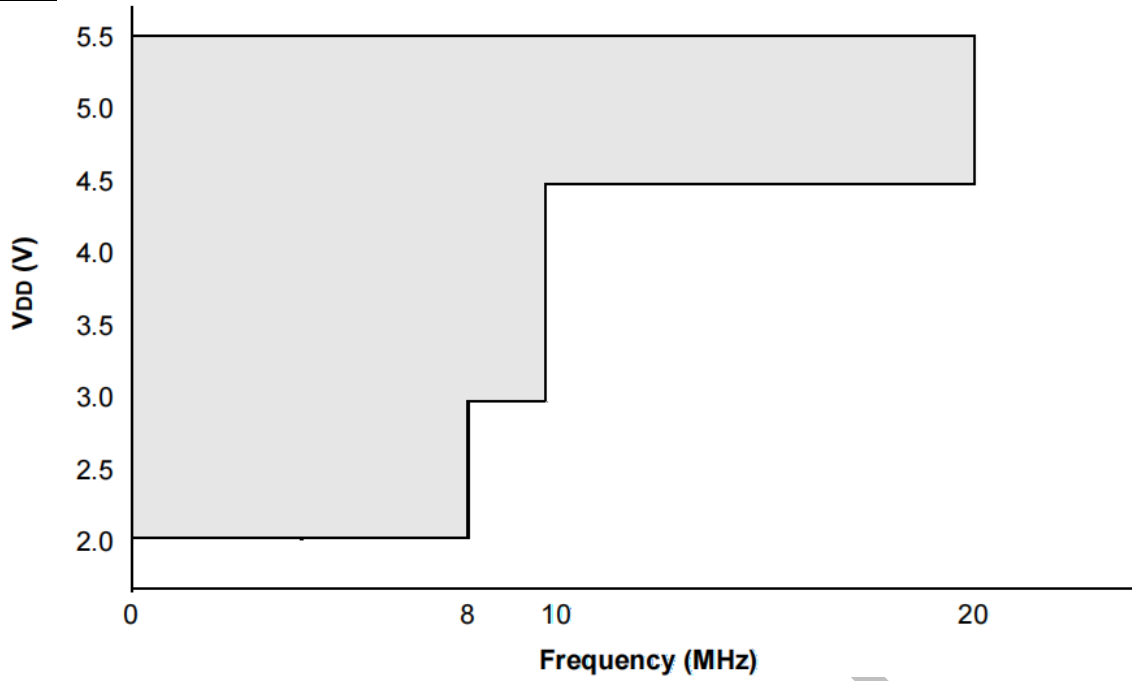

**Figure 4.** DIF81F901 VOLTAGE-FREQUENCY GRAPH,  $-40^{\circ}\text{C} \leq T_A \leq +125^{\circ}\text{C}$

**Note 1:** The shaded region indicates the permissible combinations of voltage and frequency

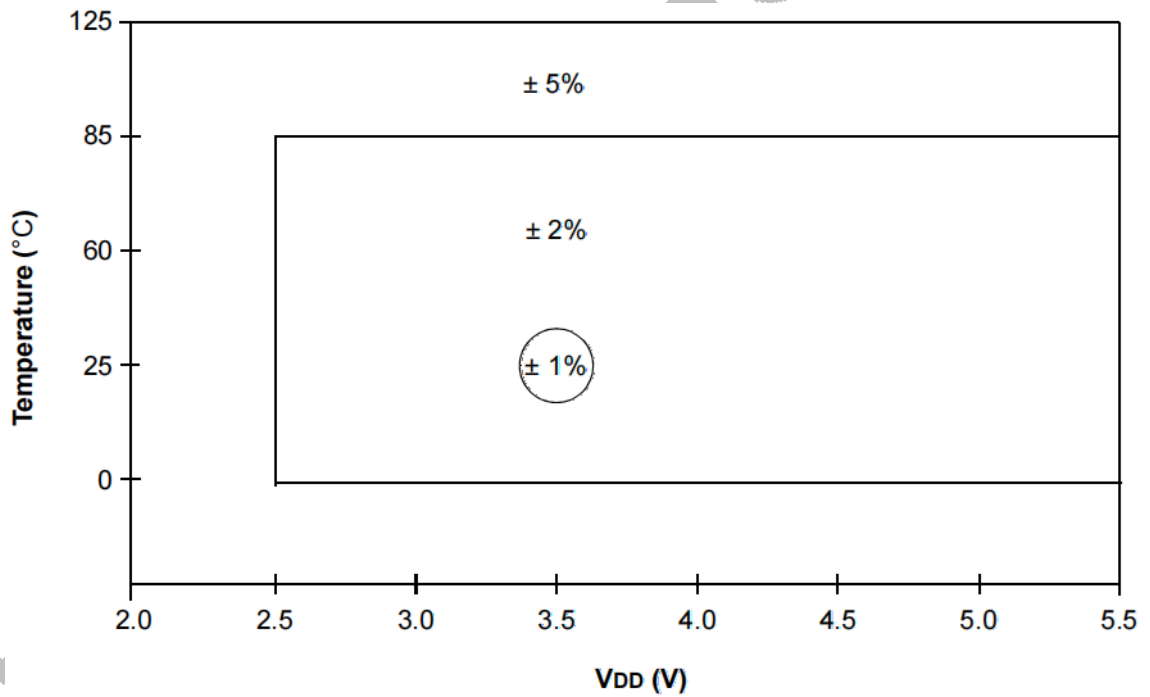

**Figure 5.** HFINTOSC FREQUENCY ACCURACY OVER DEVICE VDD AND TEMPERATURE





## DC Characteristics: DIF81F901

DC CHARACTERISTICS			Standard Operating Conditions (unless otherwise stated)				
			Operating temperature $-40^{\circ}\text{C} \leq T_A \leq +85^{\circ}\text{C}$ for industrial $-40^{\circ}\text{C} \leq T_A \leq +125^{\circ}\text{C}$ for extended				
Param No.	Sym	Characteristic	Min	Typ†	Max	Units	Conditions
D001 D001C D001D	VDD	Supply Voltage	2.0 2.0 3.0 4.5	— — — —	5.5 5.5 5.5 5.5	V V V V	Fosc $\leq$ 8 MHz: HFINTOSC, EC Fosc $\leq$ 4 MHz Fosc $\leq$ 10 MHz Fosc $\leq$ 20 MHz
D002*	VDR	RAM Data Retention Voltage <sup>(1)</sup>	1.5	—	—	V	Device in Sleep mode
D003	VPOR	VDD Start Voltage to ensure internal Power-on Reset signal	—	VSS	—	V	
D004*	SVDD	VDD Rise Rate to ensure internal Power-on Reset signal	0.05	—	—	V/ms	

\* These parameters are characterized but not tested.

† Data in "Type" column is at 5.0V, 25° C unless otherwise stated. These parameters are for design guidance only and are not tested.

**Note 1:** This is the limit to which VDD can be lowered in Sleep mode without losing RAM data.



### Package Details

DIF81F901DI, 28-Lead Skinny Plastic Dual In-Line (SP)- 300 mil Body [DIP]

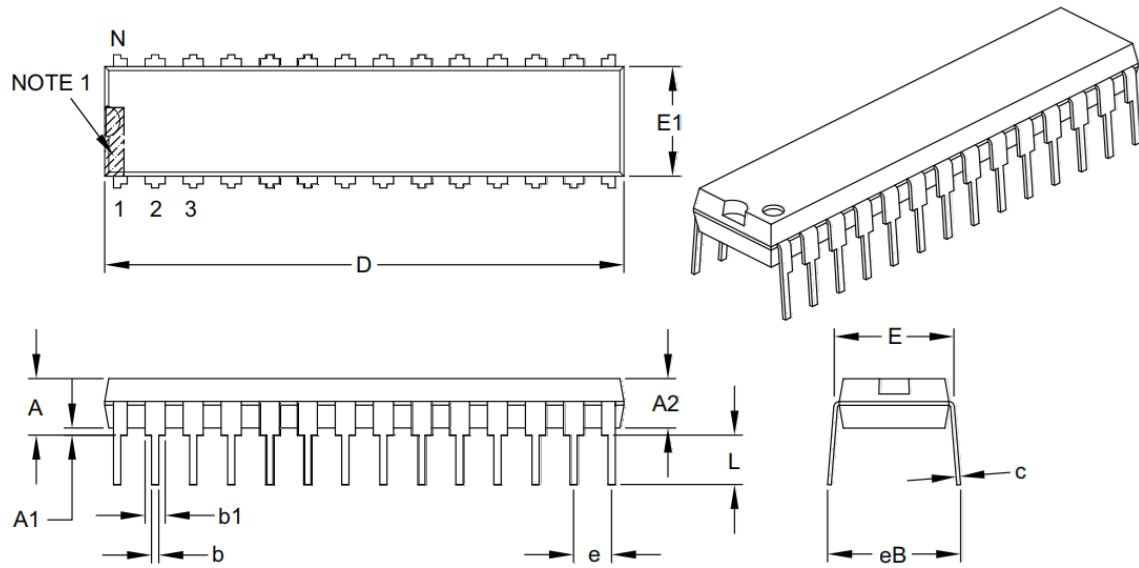

Dimension Limits	Units	INCHES		
		MIN	NOM	MAX
Number of Pins	N	28		
Pitch	e	.100 BSC		
Top to Seating Plane	A	-	-	.200
Molded Package Thickness	A2	.120	.135	.150
Base to Seating Plane	A1	.015	-	-
Shoulder to Shoulder Width	E	.290	.310	.335
Molded Package Width	E1	.240	.285	.295
Overall Length	D	1.345	1.365	1.400
Tip to Seating Plane	L	.110	.130	.150
Lead Thickness	c	.008	.010	.015
Upper Lead Width	b1	.040	.050	.070
Lower Lead Width	b	.014	.018	.022
Overall Row Spacing §	eB	-	-	.430

**Notes:**

1. Pin 1 visual index feature may vary, but must be located with the hatched area.
2. § Significant Characteristic.
3. Dimensions D and E1 do not include mold flash or protrusions. Mold flash or protrusions shall not exceed .010" per side.
4. Dimensioning and tolerancing per ASME Y14.5M.

BSC: Basic Dimension. Theoretically exact value shown without tolerances.



DIF81F901SI, 28-Lead Plastic Small Outline (SO)- Wide, 7.50 mm Body [SOIC]

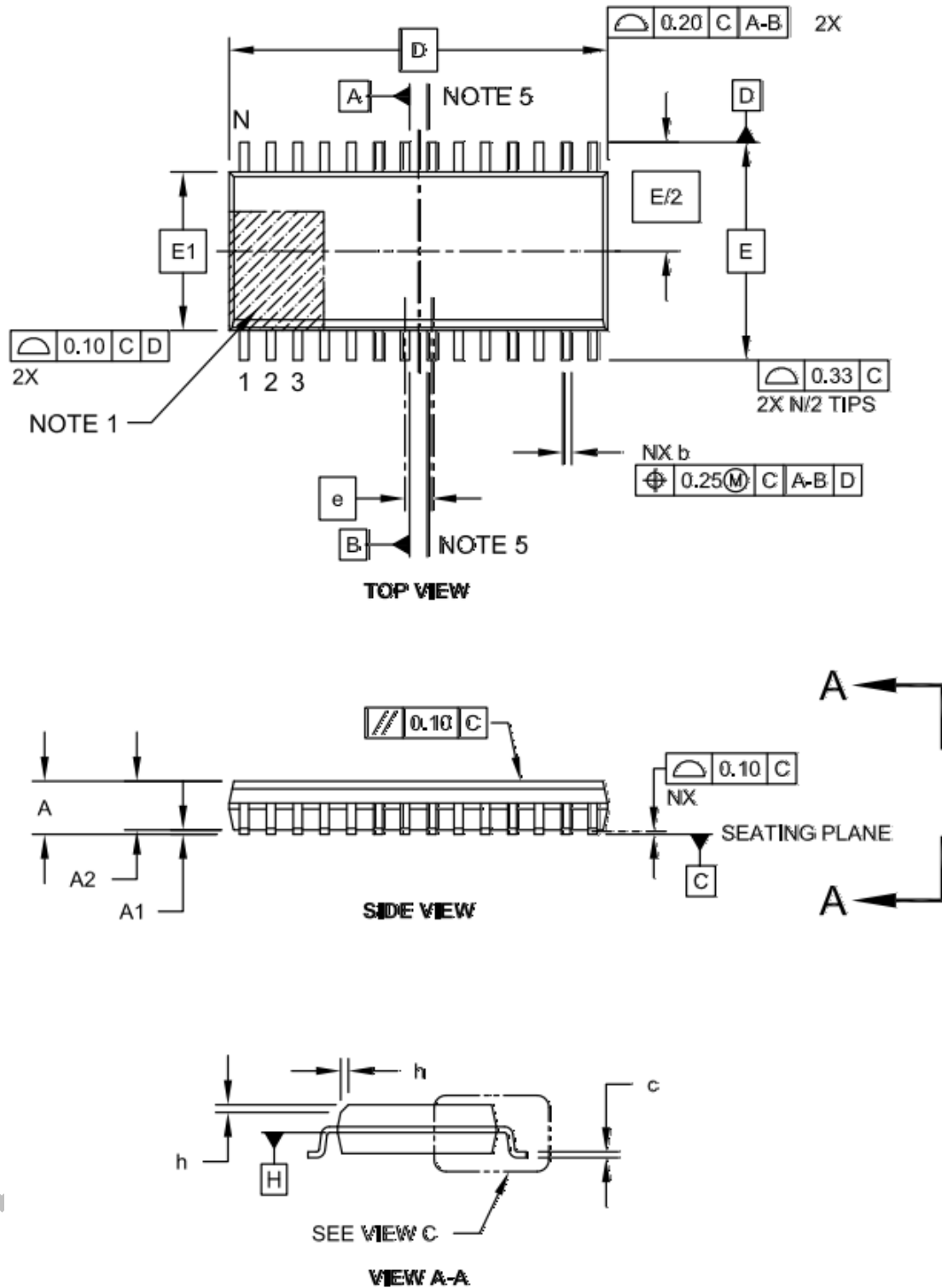



## DIF81F901SI, 28-Lead Plastic Small Outline (SO)- Wide, 7.50 mm Body [SOIC]

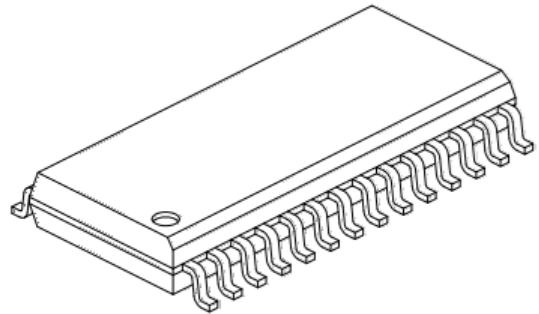
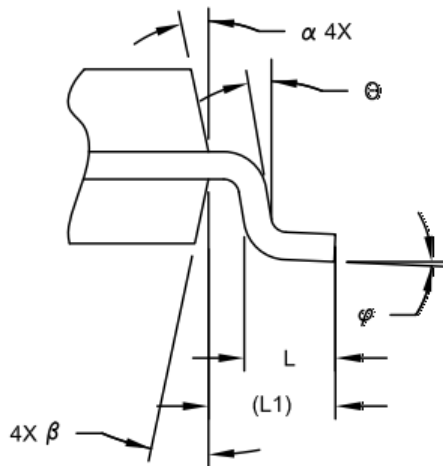

VIEW C

Dimension Limits	Units	MILLIMETERS		
		MIN	NOM	MAX
Number of Pins	N	28		
Pitch	e	1.27 BSC		
Overall Height	A	–	–	2.65
Molded Package Thickness	A2	2.05	–	–
Standoff	A1	0.10	–	0.30
Overall Width	E	10.30 BSC		
Molded Package Width	E1	7.50BSC		
Overall Length	D	17.90BSC		
Chamfer (Optional)	h	0.25	–	0.75
Foot Length	L	0.40	–	1.27
Footprint	L1	1.40 REF		
Lead Angle	$\theta$	0°	–	–
Foot Angle	$\phi$	0°	–	8°
Lead Thickness	c	0.18	–	0.33
Lead Width	b	0.31	–	0.51
Mold Draft Angle Top	$\alpha$	0°	–	0°
Mold Draft Angle Bottom	$\beta$	0°	–	0°

**Notes:**

- Pin 1 visual index feature may vary, but must be located with the hatched area.
  - § Significant Characteristic.
  - Dimensions D and E1 do not include mold flash or protrusions. Mold flash or protrusions shall not exceed .010" per side.
  - Dimensioning and tolerancing per ASME Y14.5M.
- BSC: Basic Dimension. Theoretically exact value shown without tolerances.
- REF: Reference Dimension, usually without tolerance, for information purposes only.
- Datums A & B to be determined at Datum H.



DIF81F901SI, 28-Lead Plastic Small Outline (SO)- Wide, 7.50 mm Body [SOIC]

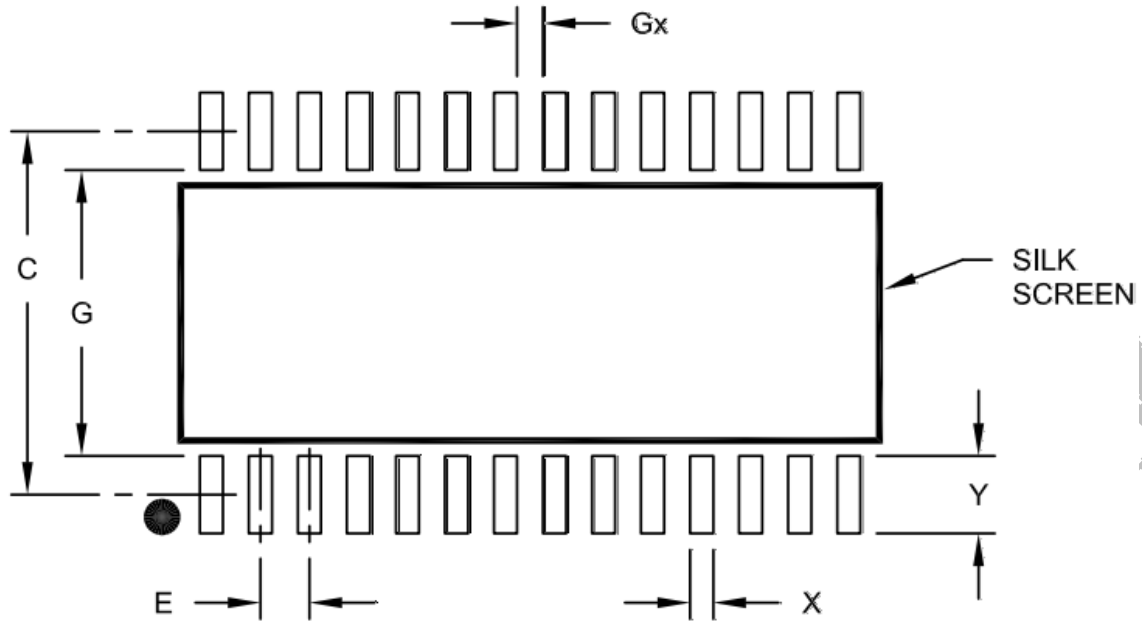

### RECOMMENDED LAND PATTERN

Dimension Limits	Units	MILLIMETERS		
		MIN	NOM	MAX
Contact Pitch	E	1.27BSC		
Contact Pad Spacing	C		9.40	
Contact Pad Width(X28)	X			0.60
Contact Pad Length(X28)	Y			2.00
Distance Between Pads	Gx	0.67		
Distance Between Pads	G	7.40		

**Notes:**

1. Dimensioning and tolerancing per ASME Y14.5M.  
BSC: Basic Dimension. Theoretically exact value shown without tolerances.

DEMO



DIF81F901XI, 28-Lead Plastic Shrink Small Outline (SS)-5.30 mm Body [SSOP]

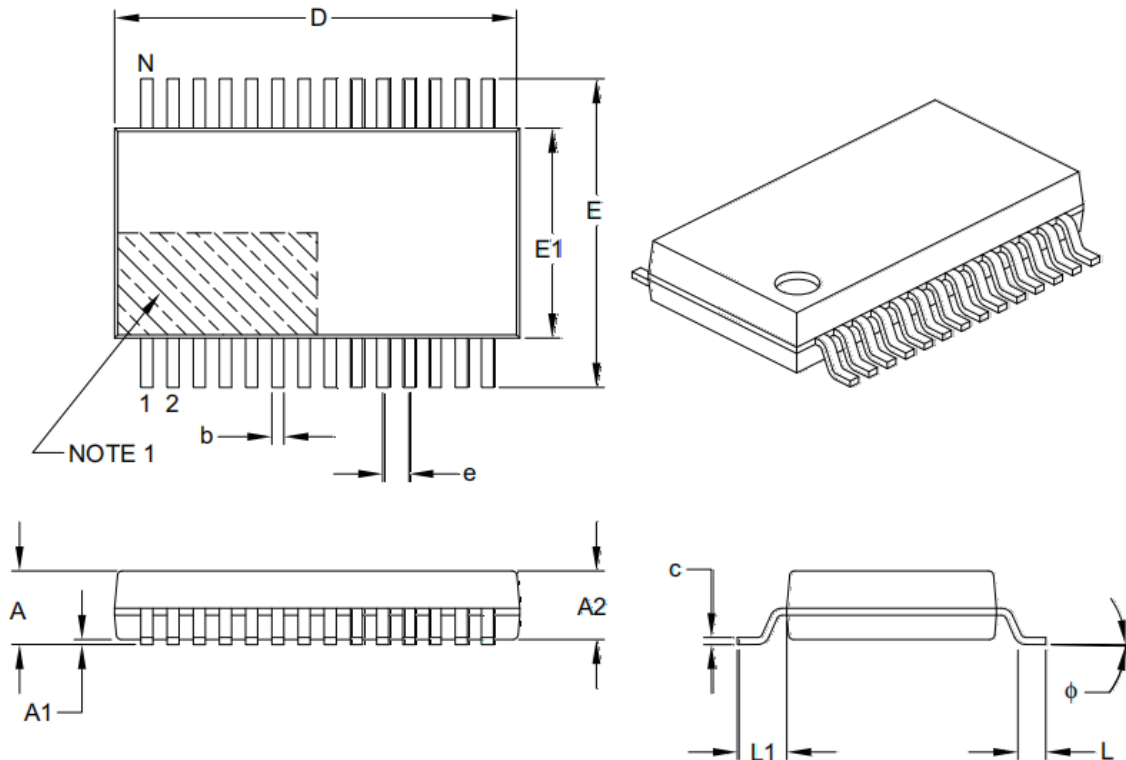

Dimension	Units	MILLIMETERS		
		MIN	NOM	MAX
Number of Pins	N	28		
Pitch	e	0.65 BSC		
Overall Height	A	-	-	2.00
Molded Package Thickness	A2	1.65	1.75	1.85
Standoff	A1	0.05	-	-
Overall Width	E	7.40	7.80	8.20
Molded Package Width	E1	5.00	5.30	5.60
Overall Length	D	9.90	10.20	10.50
Foot Length	L	0.55	0.75	0.95
Footprint	L1	1.25 REF		
Lead Thickness	c	0.09	-	0.25
Foot Angle	$\phi$	0°	4°	8°
Lead Width	b	0.22	-	0.38

Notes:

- Pin 1 visual index feature may vary, but must be located within the hatched area.
- Dimensions  $D$  and  $E1$  do not include mold flash or protrusions. Mold flash or protrusions shall not exceed 0.20 mm per side.
- Dimensioning and tolerancing per ASME Y14.5M.

BSC: Basic Dimension. Theoretically exact value shown without tolerances.

REF: Reference Dimension, usually without tolerance, for information purposes only.



DIF81F901XI, 28-Lead Plastic Shrink Small Outline (SS)-5.30 mm Body [SSOP]

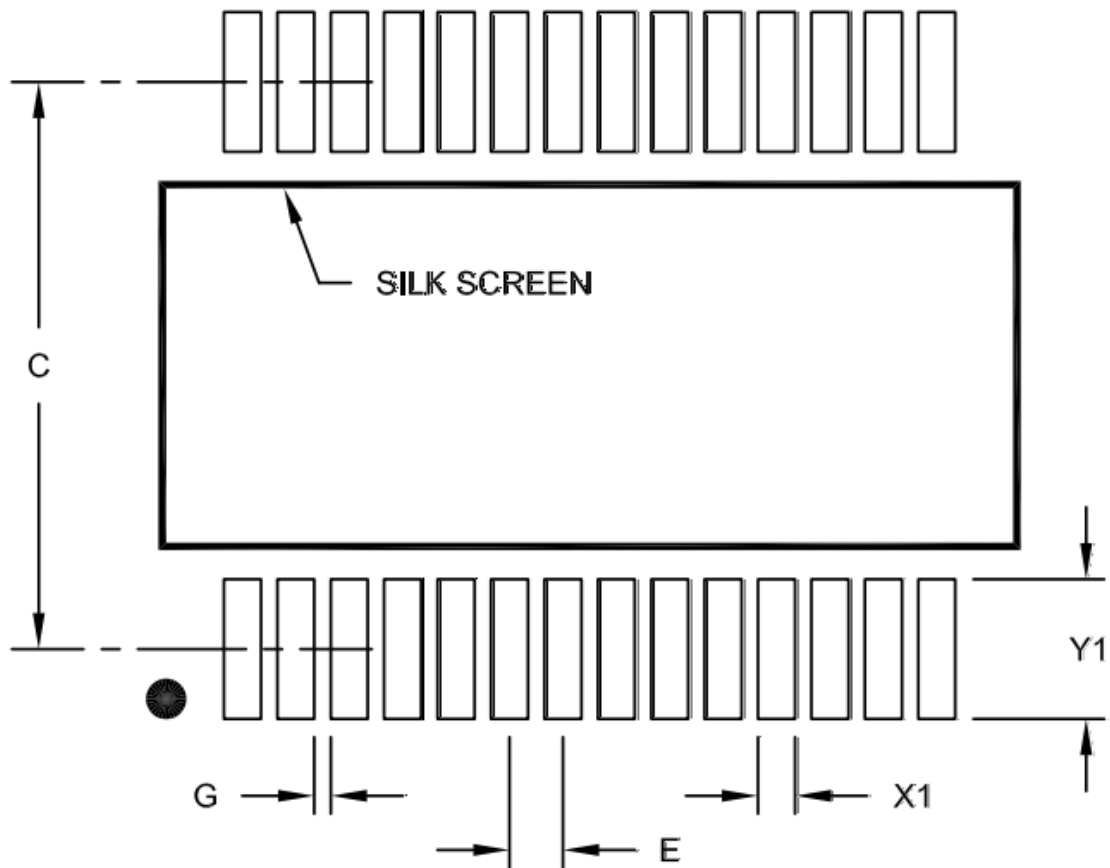

### RECOMMENDED LAND PATTERN

Dimension Limits	Units	MILLIMETERS		
		MIN	NOM	MAX
Contact Pitch	E	0.65BSC		
Contact Pad Spacing	C		7.20	
Contact Pad Width(X28)	X1			0.45
Contact Pad Length(X28)	Y1			1.75
Distance Between Pads	G	0.20		

**Notes:**

1. Dimensioning and tolerancing per ASME Y14.5M.  
BSC: Basic Dimension. Theoretically exact value shown without tolerances.

DEFINITION